

Wadkin

OPERATING AND MAINTENANCE

INSTRUCTIONS

12" PLANING AND MOULDING MACHINE, TYPE F.D.

PRINCIPAL DIMENSIONS AND CAPACITIES

Maximum size of timber admitted to feedworks ...	12 $\frac{1}{2}$ " x 6 $\frac{1}{2}$ "
Maximum size of finished work... ..	12" wide x 6" thick.
Spindle motor top and bottom heads.. ..	15 H.P. at 6,000 r.p.m.
side heads	10 H.P. at 6,000 r.p.m.
Feed motor.. ..	7 $\frac{1}{2}$ H.P.
Frequency Changer... ..	
Feed speeds.	18, 25, 32, 45, 55, 75)feet 36, 50, 64, 90, 110, 150)per min.
Length of cutterblocks top and bottom... ..	12 $\frac{1}{2}$ "
Length of cutterblocks side.	5 $\frac{1}{2}$ " or 6 $\frac{1}{2}$ "
Minimum cutting circle all heads	6 $\frac{1}{2}$ " cutting diameter
Maximum cutting circle 1st bottom head.. ..	6 $\frac{1}{2}$ "
Maximum cutting circle top heads	10 $\frac{1}{2}$ "
Maximum cutting circle side heads... ..	9"
Maximum cutting circle optional 2nd bottom head.	10 $\frac{1}{2}$ "
End adjustment all heads	$\frac{3}{4}$ "
Diameter of feed rolls.. ..	10" diameter
Diameter of spindle ends (side heads)... ..	1.13/16"
Diameter of spindle ends (horizontal heads)....	

DETAILS INCLUDED WITH MACHINE

- All motors and control gear and all wiring.
- Frequency Changer and wiring.
- Main isolating switch.
- One square cutterblock to each head complete with collets/self centring sleeves.
- Cutter bolts, nuts and cutters.
- Exhaust hoods to each head.
- Frequency changer guard and feed motor guard.

INSTALLATION

THE MACHINE is dispatched from the Works with all bright surfaces greased to prevent rusting. This must be removed by applying a cloth damped with paraffin.

FOUNDATIONS.

$\frac{3}{4}$ " diameter foundation bolts should be used to bolt the machine down to the floor. If the mill floor consists of 6" solid concrete no special foundation is necessary. Rag type holding down bolts may be used and working from the foundation plan 6" to 8" square holes should be cut in the concrete for these bolts after the machine has been carefully levelled. No pit is required under the machine.

WIRING.

See Wiring diagram drawing.

DUST EXHAUST SYSTEM.

We have developed with Messrs. Dallow, Lambert & Co. Ltd., a special collector unit for this machine which represents a big advance on the usual practice of coupling each head independently into the main. This unit comprises a sheet steel hollow rectangular column supporting all the overhead pipes to the top head and side heads, and the rigid connections to the bottom blocks. The flexible pipes are spring counter-balanced to facilitate removal of the exhaust hoods. It is not necessary to break the connection between hood and pipe as the counterbalance spring is strong enough to support each hood and piping above the machine clear of the operator.

FEED WORKS.

Single speed driving motor to a six speed gear box, a two step cone drive giving 12 feed speeds. The gear box drives a main input shaft which through a chain and gears, drives bottom and top rollers. The top rolls are mounted on a vertical vee slide which slides in the main feedworks housing. Top rolls have an outer roller bearing support which can be easily removed to fit special feed rollers.

Provision is made for re-tensioning the main driving chain inside the feedworks housing and the whole drive runs in an oil bath. Spiral gear box mounted at the top of the feedworks provides the drive for raising and lowering the top feed rolls. The rollers have independent spring adjustment by turning the hand-wheels on the top roller cover. A timber gate is fitted to the top roll cover and should be set to avoid an oversize board being fed into the machine. The bottom rolls are ball bearing mounted and are adjustable from the front of the machine by screw and taper wedges. An extra screw adjustment is provided to enable bottom rolls to be pitched up or down. This adjustment to be done to special instructions. (See Page)

A master foot operating lever is fitted to stop the feed and also to be used when gear box selection levers are used. By using this foot lever making the gear box driving belt slip, gear change can be done without crashing the gears. The main feedworks driving motor guard can be easily removed and the driving belt can be changed to the second cone pulley by pressing down a foot lever which moves the motor. The driving motor is spring loaded on the pivoting brackets. The frequency changer drive is mounted on the end of the main frame, flat belt driving the frequency changer. An adjustment is provided to take up any slack in the belt.

TABLE BEFORE 1ST BOTTOM HEAD

The adjustable table before the 1st bottom head is mounted on an angular vee slide. The adjustment is through spiral gears and screws and can be done from the front of the machine. A lock is on the cross shaft for use after final setting has been done. The bed plate table is adjustable and can be locked in position by a vee wedge (Important : See that this table is always locked after setting).

The side pressure after 2nd feed roll can be used for stock up to 6" wide only, this pressure will have to be removed for stock wider than 6".

ROLLER PRESSURE OVER 1ST BOTTOM HEAD

Three roller pressure units are carried from a cross slide fitted to the bottom head stand.

The pressures can be adjusted up or down by a shaft on the front of the machine. Each roller has a spring loaded plunger. The cross slide is fitted with wear strip and can be locked in position, after final setting.

This roller pressure can be used in place of the pad pressures between fence side heads if specially ordered.

Adjustment for Raise and
Fall of Bottom Roll.

Slacken lock before
adjusting rolls. Re-lock
after final setting.

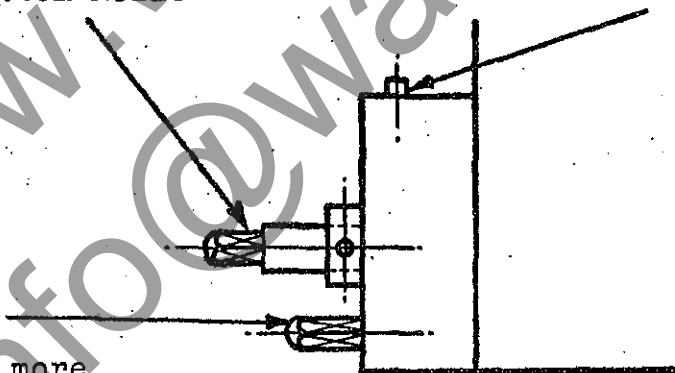

To pitch bottom rolls.
Important. Do not pitch more
than .020" if this is over done
bottom roll shaft will lock.

THE SPINDLE CARRIAGE IS MOUNTED ON A DOUBLE SQUARE SLIDE. RISE AND FALL IS DONE THROUGH TWO TOTALLY ENCLOSED SPIRAL GEAR BOXES AND OPERATED BY SHAFT (D) BEFORE ADJUSTING HEIGHT OF SPINDLE UNIT PULL LEVER (C) UP, RAISE OR LOWER SPINDLE UNIT AND RE+LOCK AFTER BLOCK HAS BEEN SET. CROSS ADJUSTMENT OF SPINDLE IS PROVIDED. SLACKEN OFF NUTS (E) AND ALSO NUT ON OUTBOARD BEARING (E1) RATCHET LEVER FOR HORIZONTAL ADJUSTMENT. RE-LOCK NUTS AFTER FINAL SETTING. TO REMOVE OUTBOARD BEARING FROM END OF THE SPINDLE. SLACKEN NUTS (E1) AND (B) AND SLIDE OUTBOARD UNIT INTO LUGS ON THE SPINDLE CARRIAGE. OUTBOARD BEARINGS ARE FITTED WITH TAPER CONES AND CAN BE LOCKED ON THE SPINDLE AFTER FINAL SETTING HAS BEEN DONE CHIPS ARE EXHAUSTED THROUGH A CHUTE THE MAIN FRAME TO THE BACK OF THE MACHINE (MINIMUM CUTTING CIRCLE 6½) (MAXIMUM CUTTING CIRCLE 7½) TAPER GIBS ARE FITTED TO THE SPINDLE CARRIAGE AND SHOULD BE ADJUSTED TO TAKE UP WEAR ON THE SLIDE. (SEE BELOW AND PAGE 7 FOR DIAGRAMS)

SKF 402353 BRG.

HOFF BRG. No. N.1074

HOFF BRG. No. N.1074

30 x 62 x 16 M/M.

55 x 120 x 29 M/M.

55 x 120 x 29 M/M.

OUTBOARD BEARING.

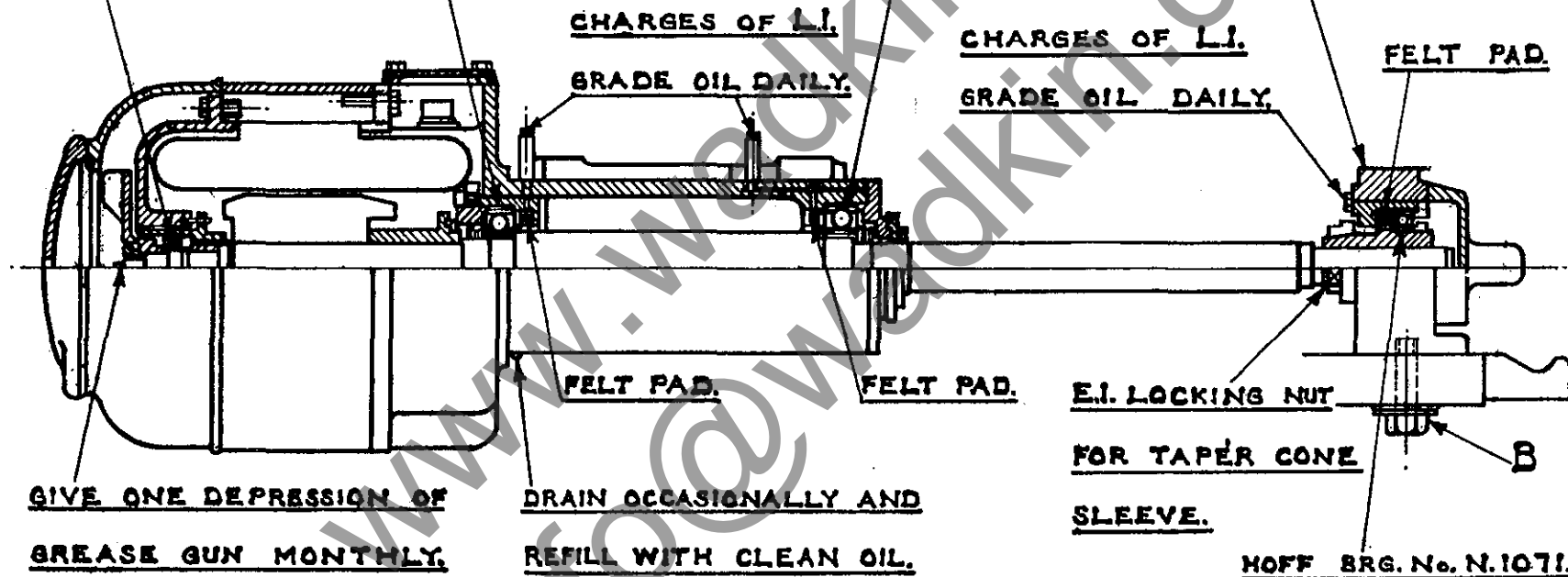

GIVE ONE DEPRESSION OF
GREASE GUN MONTHLY.

DRAIN OCCASIONALLY AND
REFILL WITH CLEAN OIL.

E1. LOCKING NUT
FOR TAPER CONE
SLEEVE.

HOFF BRG. No. N.1071.

55 x 100 x 21 M/M.

OILING SYSTEM COVERED BY WADKIN LTD., PATENT.

THE SPINDLE CARRIAGE IS MOUNTED ON A DOUBLE SQUARE SLIDE. RISE AND FALL IS DONE THROUGH TWO TOTALLY ENCLOSED SPIRAL GEAR BOXES AND OPERATED BY SHAFT (D) BEFORE ADJUSTING HEIGHT OF SPINDLE UNIT PULL LEVER (C) UP, RAISE OR LOWER SPINDLE UNIT AND RE-LOCK AFTER BLOCK HAS BEEN SET. CROSS ADJUSTMENT OF SPINDLE IS PROVIDED. SLACKEN OFF NUTS (E) AND ALSO NUT ON OUTBOARD BEARING (E.I.) RATCHET LEVER FOR HORIZONTAL ADJUSTMENT. RE-LOCK NUTS AFTER FINAL SETTING. TO REMOVE OUTBOARD BEARING FROM END OF THE SPINDLE. SLACKEN NUTS (E.I.) AND (B) AND SLIDE OUTBOARD UNIT INTO LUGS ON THE SPINDLE CARRIAGE. OUTBOARD BEARINGS ARE FITTED WITH TAPER CONES AND CAN BE LOCKED ON THE SPINDLE AFTER FINAL SETTING HAS BEEN DONE CHIPS ARE EXHAUSTED THROUGH A CHUTE THE MAIN FRAME TO THE BACK OF THE MACHINE (MINIMUM CUTTING CIRCLE 6½) (MAXIMUM CUTTING CIRCLE 7½) TAPER GIBS ARE FITTED TO THE SPINDLE CARRIAGE AND SHOULD BE ADJUSTED TO TAKE UP WEAR ON THE SLIDE. (SEE BELOW AND PAGE 7 FOR DIAGRAMS.)

SKF 402353 BRG.

HOFF BRG. No. N.1074

HOFF BRG. No. N. 5449.

30 x 62 x 16 M/M.

55 x 120 x 29 M/M.

60 x 130 x 31 M/M.

OUTBOARD BEARING.

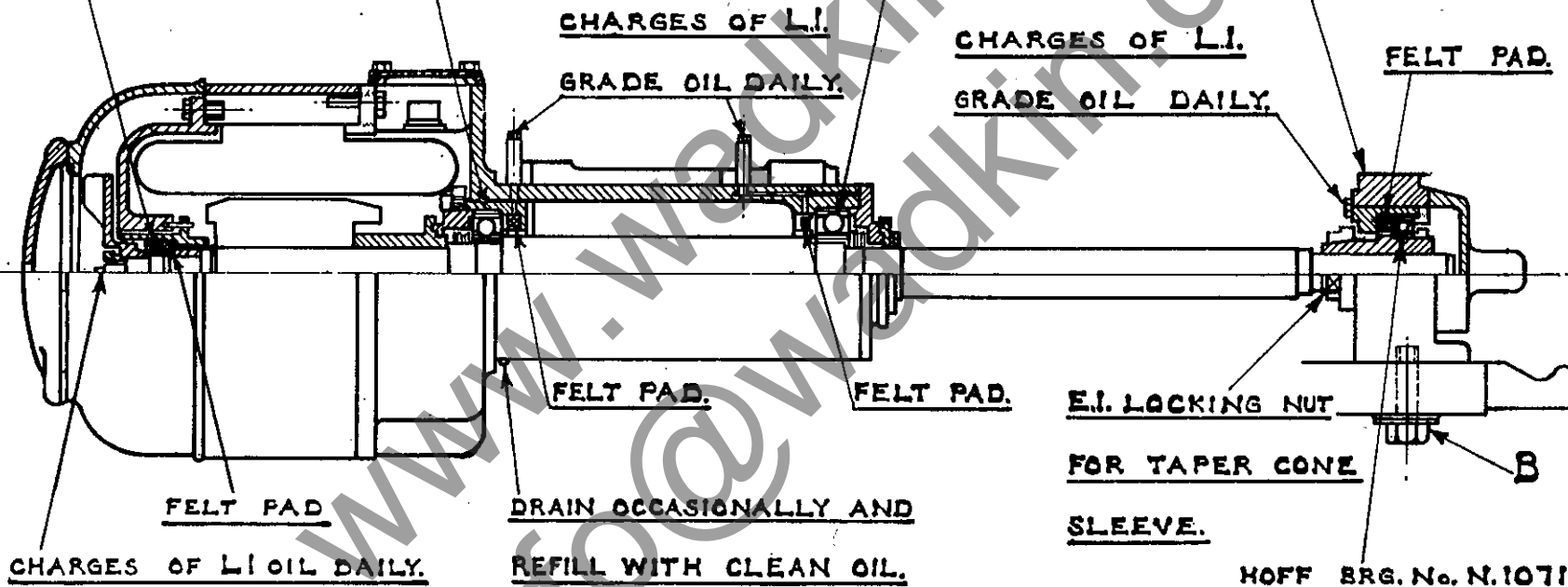

OILING SYSTEM COVERED BY WADKIN LTD., PATENT.

HOFF BRG. No. N.1071.
55x100x 21 M/M.

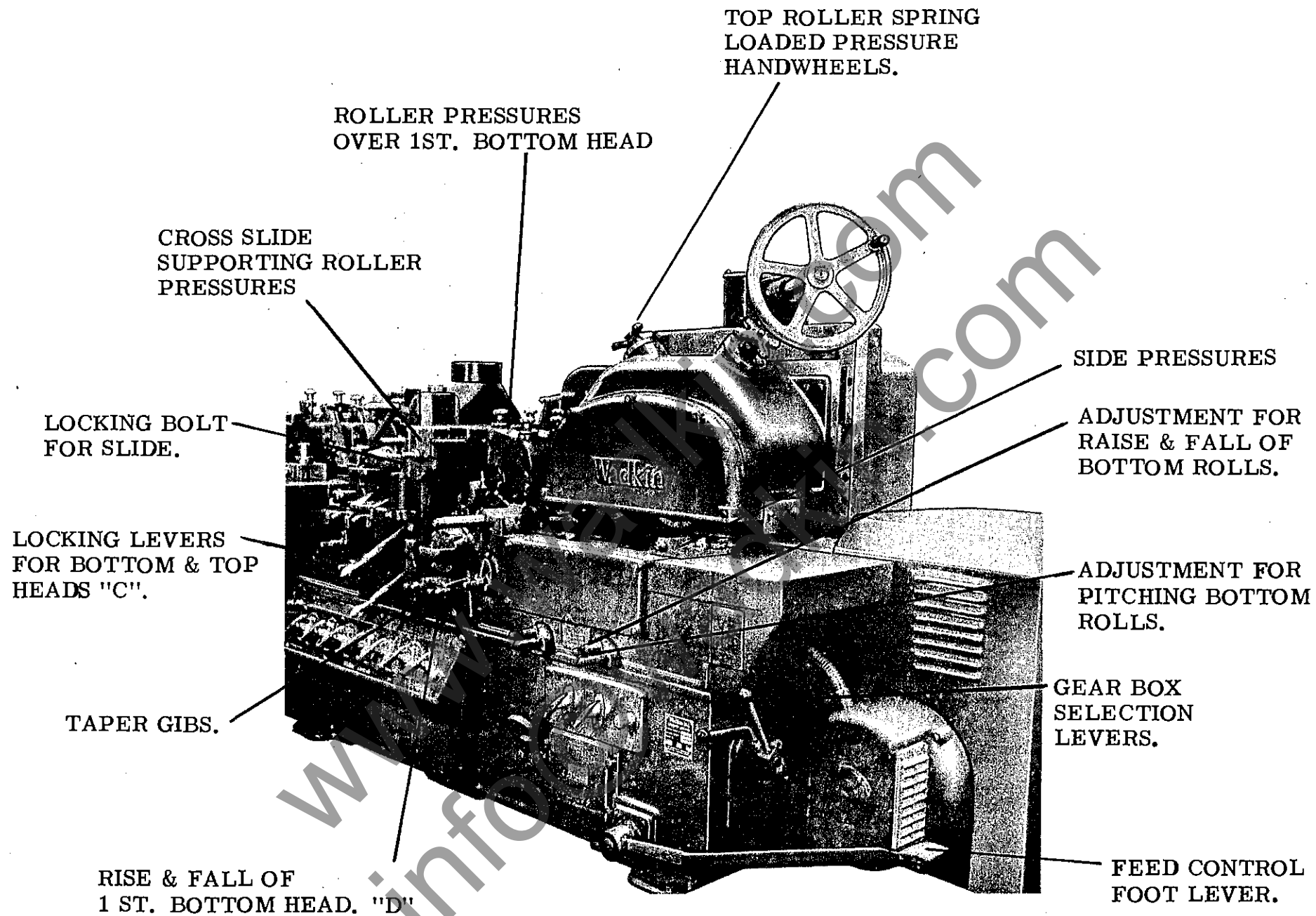

The spindle unit is mounted on a double vertical slide located and locked on each side of the cutterblock with locking levers (A). Taper gibs are fitted front and rear on the spindle carriage to take up any wear.

Rise and fall of spindle unit is by two vertical screws operated by spiral gears housed in the spindle carriage and operated by shaft (B).

Before adjusting height of spindle pull lever up and raise or lower spindle unit, relock after final setting.

The bed plates under the top heads are renewable and are gripped in position with a wedge action.

Ratchet lever provides the cross adjustment to the spindle; a scale is fitted to the vertical stands with a pointer fixed to the carriage slide, giving direct reading for adjusting cutterheads.

2 ND. TOP HEAD.

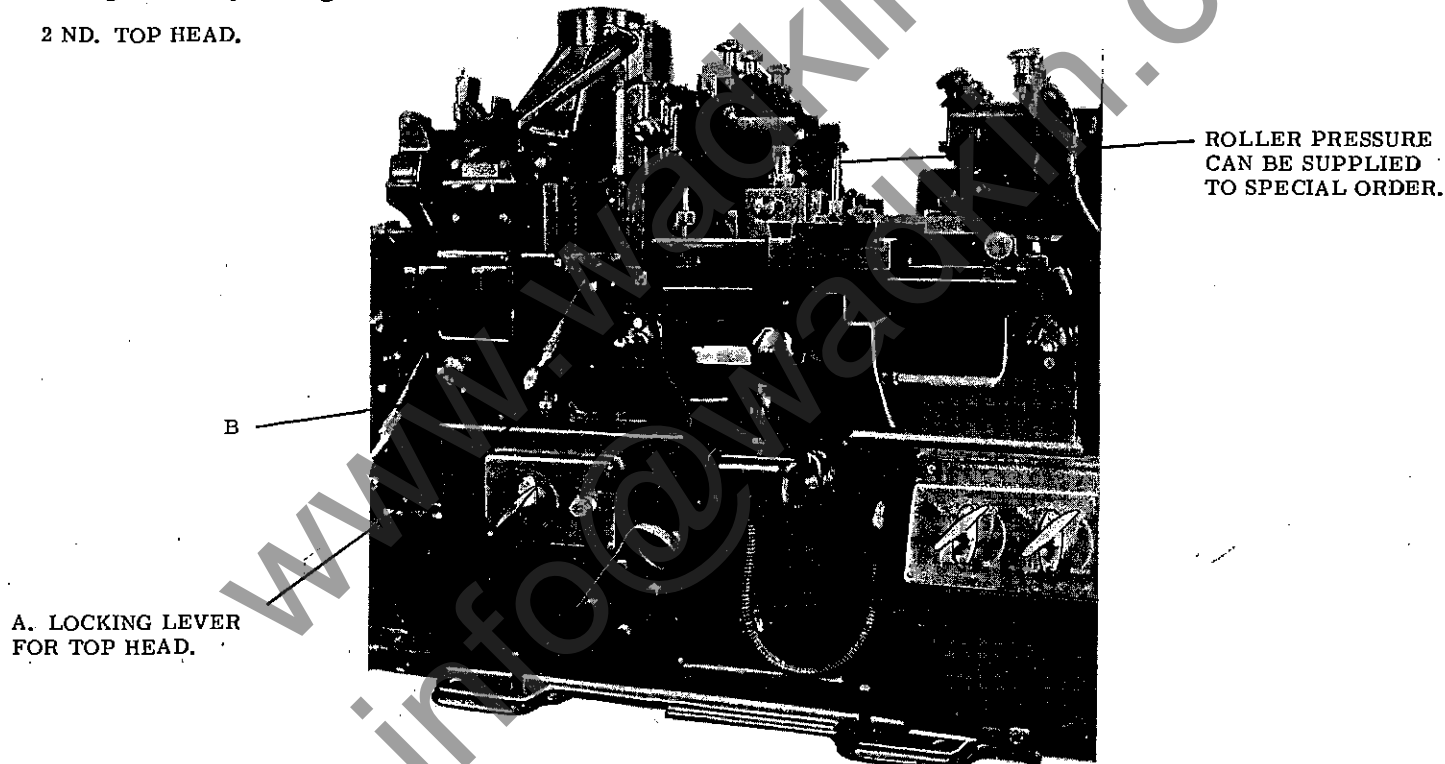

A. LOCKING LEVER FOR TOP HEAD.

ROLLER PRESSURE CAN BE SUPPLIED TO SPECIAL ORDER.

The chipbreaker unit is fitted with independent spring loaded pressure shoes pivoting at (A). The unit slides along supporting arms (B) and is locked in position with serrated washer and nuts (C) each side of unit. Square head screws (D) can be adjusted to limit the amount of movement back of each shoe.

Renewable pressure shoes are fitted with stellite tips. Variation in stock is controlled by the whole of the chipbreaker unit swinging up against spring (E). Stops are fitted to the spindle carriage and outboard bearing unit and can be adjusted to suit class of work being done. The chipbreaker can be swung over against stops to enable setting of the cutterblock. Minimum cutting circle $6\frac{1}{2}$ " diameter. Maximum cutting circle $10\frac{1}{2}$ " diameter.

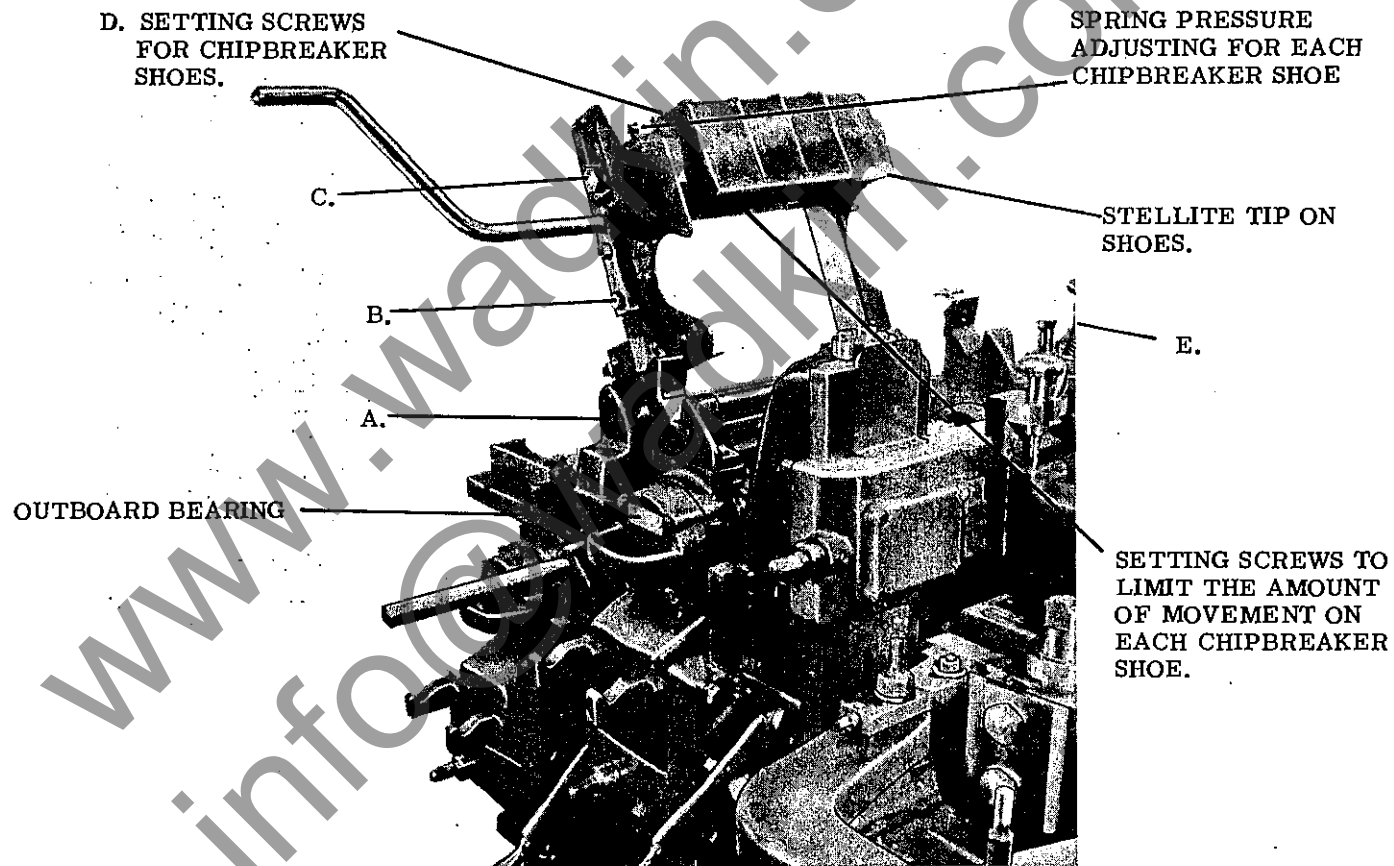

SIDE HEADS.

PUMP CHARGES
OF GRADE LI OIL
DAILY.

HOFF. BRG. No. 1071
55 x 100 x 21 M/M.

FELT PADS.

SURPLUS OIL
OUTLET AT REAR
OF SPINDLE BARREL.

HOFF. BRG. No. 1072
43 x 100 x 25 M/M.

SKF 402353
BRG. 30 x 62 x
16 M/M.

GREASE NIPPLE.
GIVE ONE DEPRESSION
OF GREASE GUN MONTHLY.

PUMP CHARGES
OF GRADE LI
OIL DAILY.

OIL AROUND
BARREL
WEEKLY.

THE VERTICAL SIDE HEAD CUTTER SPINDLE IS CLAMPED IN A CIRCULAR HOUSING FORMING A SLIDE FOR A VERTICAL ADJUSTMENT. FOR VERTICAL ADJUSTMENT SLACKEN OFF NUT () AND USE RATCHET LEVER TO RAISE OR LOWER CUTTERBLOCK.

CROSS SCREW ADJUSTMENT TO EACH SIDE HEAD IS FITTED ON THE FRONT OF THE MACHINE, SLACKEN OFF NUT (), ADJUST IN OR OUT AND RE-LOCK SIDE HEAD. BEDPLATES ARE ADJUSTABLE AND ARE LOCKED IN POSITION BY TWO LOCKING BOLTS ON THE UNDER SIDE OF THE BED PLATES.

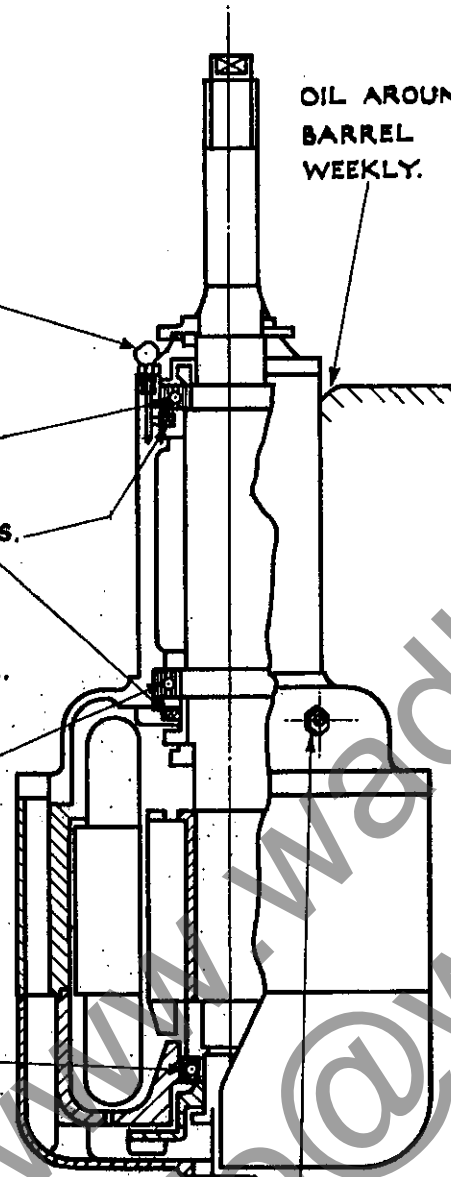

NEAR SIDE HEAD

SHAFT FOR CROSS
ADJUSTMENT FOR
NEAR SIDE HEAD.

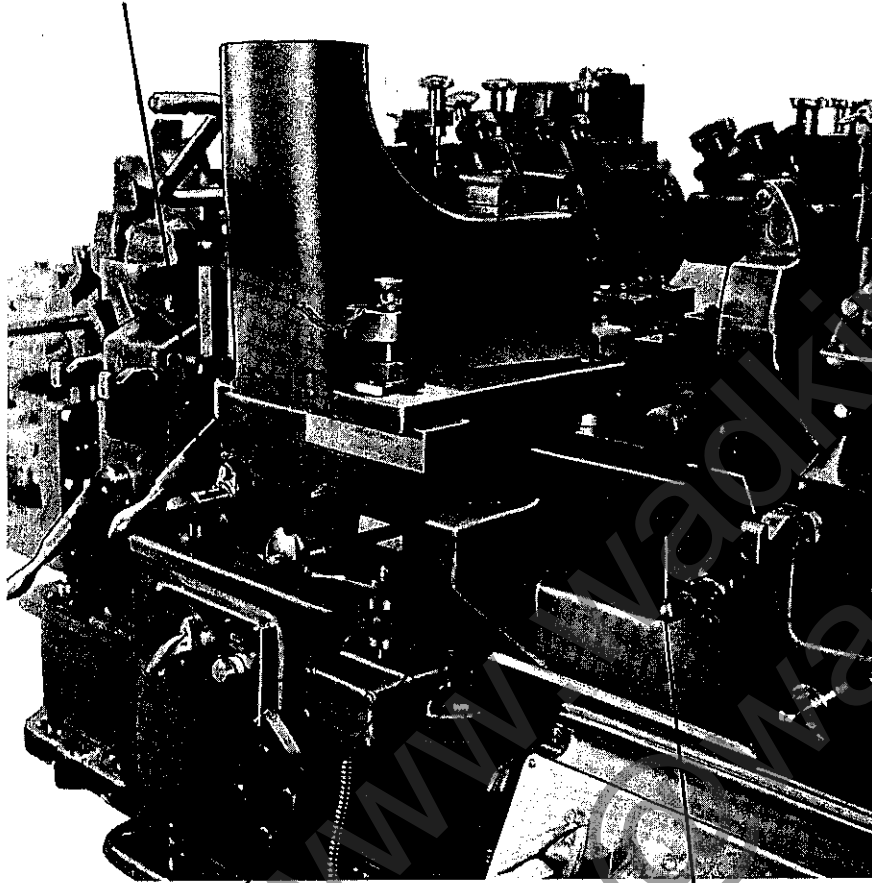

LOCKING NUT FOR
SPINDLE BARREL

SHAFT FOR CROSS
ADJUSTMENT FOR
FENCE SIDE HEAD.

FENCE SIDE HEAD

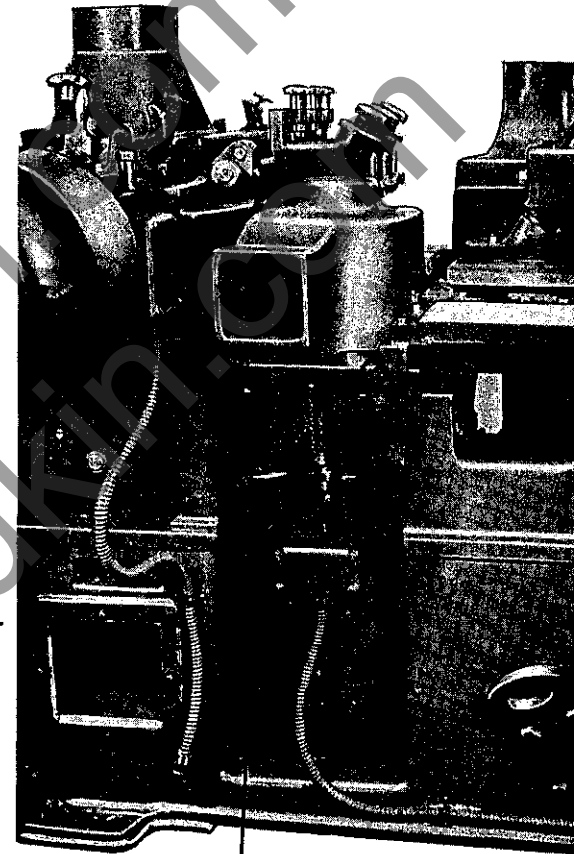

RATCHET LEVER FOR
RISE & FALL OF BLOCK.

THE SIDE HEAD CHIPBREAKER IS CARRIED FROM THE SIDE HEAD SLIDE AND MOVES WITH NEAR SIDE HEAD ADJUSTMENT. WHEN CHIPBREAKER SHOE NEEDS ADJUSTING TO SUIT CUTTERS, SLACKEN NUT (B), LIFT SERRATED WASHER, MOVE CHIPBREAKER ARM AND THEN RE-LOCK NUT. A RENEWABLE CHIPBREAKER SHOE IS FITTED WITH A STELLITE TIP, A SIDE ROLLER IS FITTED IN THE CHIPBREAKER ARM TO AVOID JAMMING ON AN EXTRA WIDE BOARD. THE SPRING PROVIDES THE TENSION TO THE CHIPBREAKER ARM AND CAN BE ADJUSTED BY TWO LOCKNUTS INSIDE THE SIDE FRAMES. FOR QUICK RELEASE IT IS ONLY NECESSARY TO SLACKEN HANDWHEEL (C) AND THE WHOLE CHIPBREAKER WILL SWING CLEAR IN THE DIRECTION OF ARROW GIVING ACCESS TO CUTTERBLOCK.

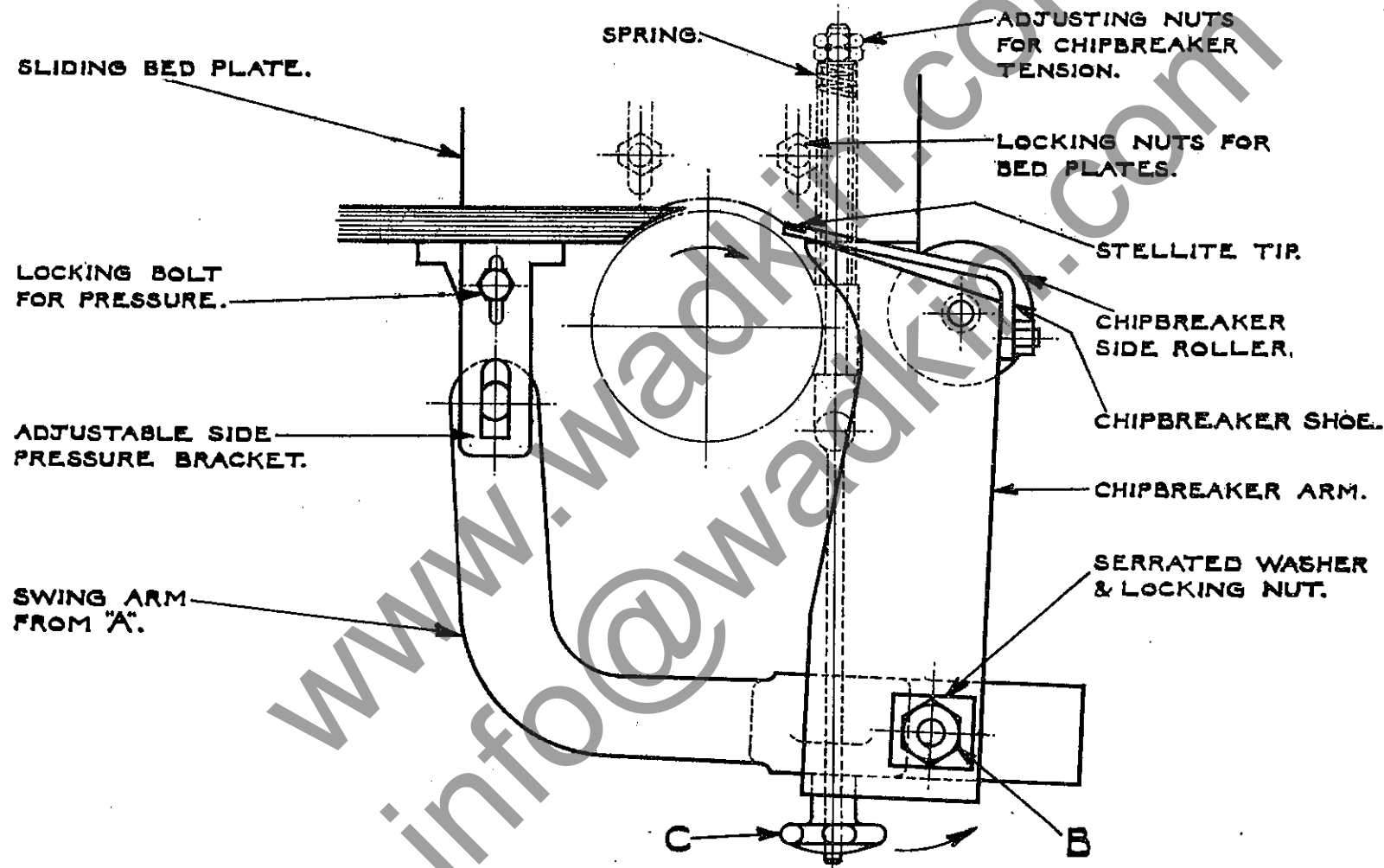

SIDE PRESSURES.

- (1) First side pressure before first roll is mounted in a tee slot on the front bottom roll housing. The spring loaded roller is flexible enough to allow timber variations up to a maximum of $\frac{3}{4}$ " without altering the setting of the unit.
- (2) Second side pressure before Bottom Head.
This pressure is carried from the front feedworks housing. A shaft support to the spring loaded roller, slacken off two-ball handle (), slide in or out. Re-lock after setting.
(Note: These pressures can only be used for stock up to 6" wide.)
- (3) Side Roller Pressure after Front Side Head.
This pressure is the same type as the 1st side pressures.
- (4) Pad Pressures after Front Side Head.
This pressure moves in or out with the adjustment of the front side spindle unit, a fine screw adjustment is fitted for the pad pressure bracket and can be locked in position after setting. The pressure bracket is drilled for wood screws for fixing wood pressures.
- (5) Side Pressure after 2nd Top Head.
Pressure consists of a bracket with a pressure plate on a supporting shaft, sliding in a bracket. The plate is drilled to enable wood pressure pads to be fitted.
- (6) Outfeed Fences on a 6-head Machine Only.
The fences are adjustable along tee slots in the table. The fences are drilled to take wood packing pieces.

2ND BOTTOM HEAD.

The Spindle unit is mounted on a double vertical slide located and locked on each side of the cutterblock with lever (). Rise and fall of spindle unit is by two vertical screws operated by spiral gears in the spindle carriage and can be adjusted by shaft (). Re-lock after block has been set. Taper gibs are fitted on the spindle carriage to take up any wear on the slides.

To allow access to cutter spindle, the whole of the outfeed table swings away from the carriage slide. To do this, fluted handwheels () should be released and the eyebolts swung out of position giving access to the cutters, the table is counterbalanced. The table is on an angle slide and can be adjusted by handwheel ().

The table itself has two tee slots cut across for outfeed fences, both fences being drilled to fit wood packings if required. Table can be adjusted by slackening off nut. Make sure that this nut is locked again after final setting.

Maximum cutting circle - - $10\frac{1}{2}$ " diameter.
Maximum cutting circle - - $6\frac{1}{2}$ " diameter.

TOP PRESSURES

ROLLER PRESSURE OVER 1ST. BOTTOM HEAD.

THREE ROLLER PRESSURE UNITS ARE FITTED OVER THE BOTTOM HEAD EACH HAVING SPRING LOADED PLUNGER ADJUSTMENT. THE ROLLER SUPPORTING BRACKET CAN BE ADJUSTED ACROSS THE STOCK BY SLACKENING OFF NUTS (E). RE-LOCK AFTER SETTING. THE COMPLETE ROLLER UNITS MOVE UP OR DOWN ON A CROSS SLIDE CARRIED FROM THE BOTTOM HEAD STAND.

THIS ROLLER COULD BE USED IN PLACE OF PAD PRESSURE BETWEEN FRONT SIDE HEAD IF ORDERED.

TOP PAD PRESSURES AFTER TOP HEADS.

PRESSURES ARE CARRIED FROM THE CHIPBREAKER SUPPORT (A) AND MOVE UP OR DOWN WITH THE SPINDLE UNIT WHEN ADJUSTED. FOR FINAL SETTING USE STAR HANDWHEELS (B). NOTE NUTS (C) TO BE SLACKENED OFF BEFORE TURNING HANDWHEELS (B). RE-LOCK AFTER FINAL SETTING. FOR EXTRA SPRING PRESSURE TO SHOES TURN KNURLED HANDWHEELS (D). PRESSURE SHOES ARE FITTED WITH REMOVABLE STEEL PLATES FOR SUPPORTING WOOD PRESSURE SHOES.

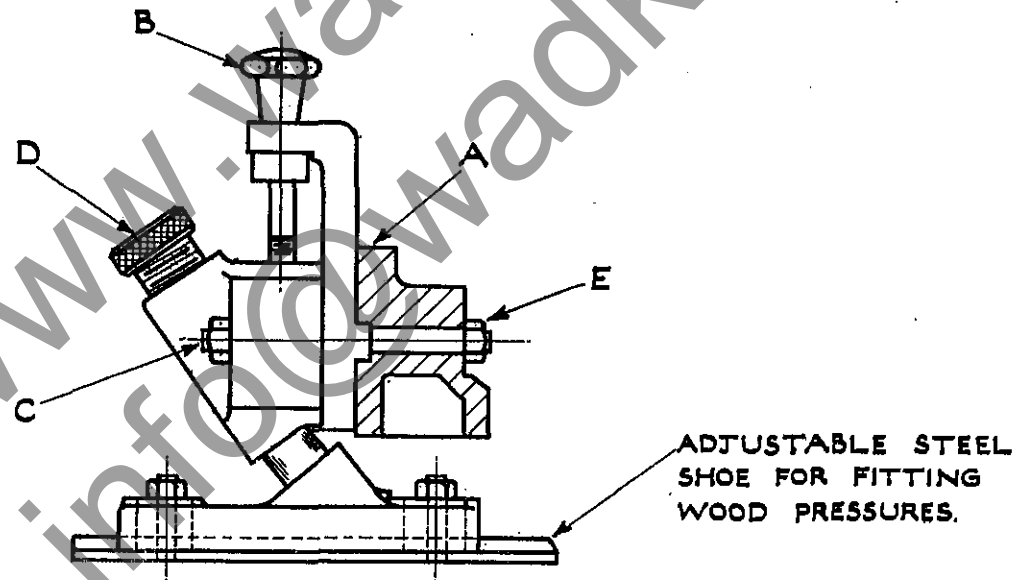

- Points B. Oil weekly 3 to 4 drops Wadkin Oil Grade L. 4.
- Points C. End of motor un its and out-board bearing units 1 charge of grease gun weekly. Wadkin Grease Grade L. 6.
- Points D. Oil Spindles to instructions on pages 6 and 10.
- Points E. Remove cover and oil swing bracket and give 1 charge of the grease gun to the roller swing carriage housings.
- Points F. Bottom shafts give 1 charge of grease gun every 2 months.

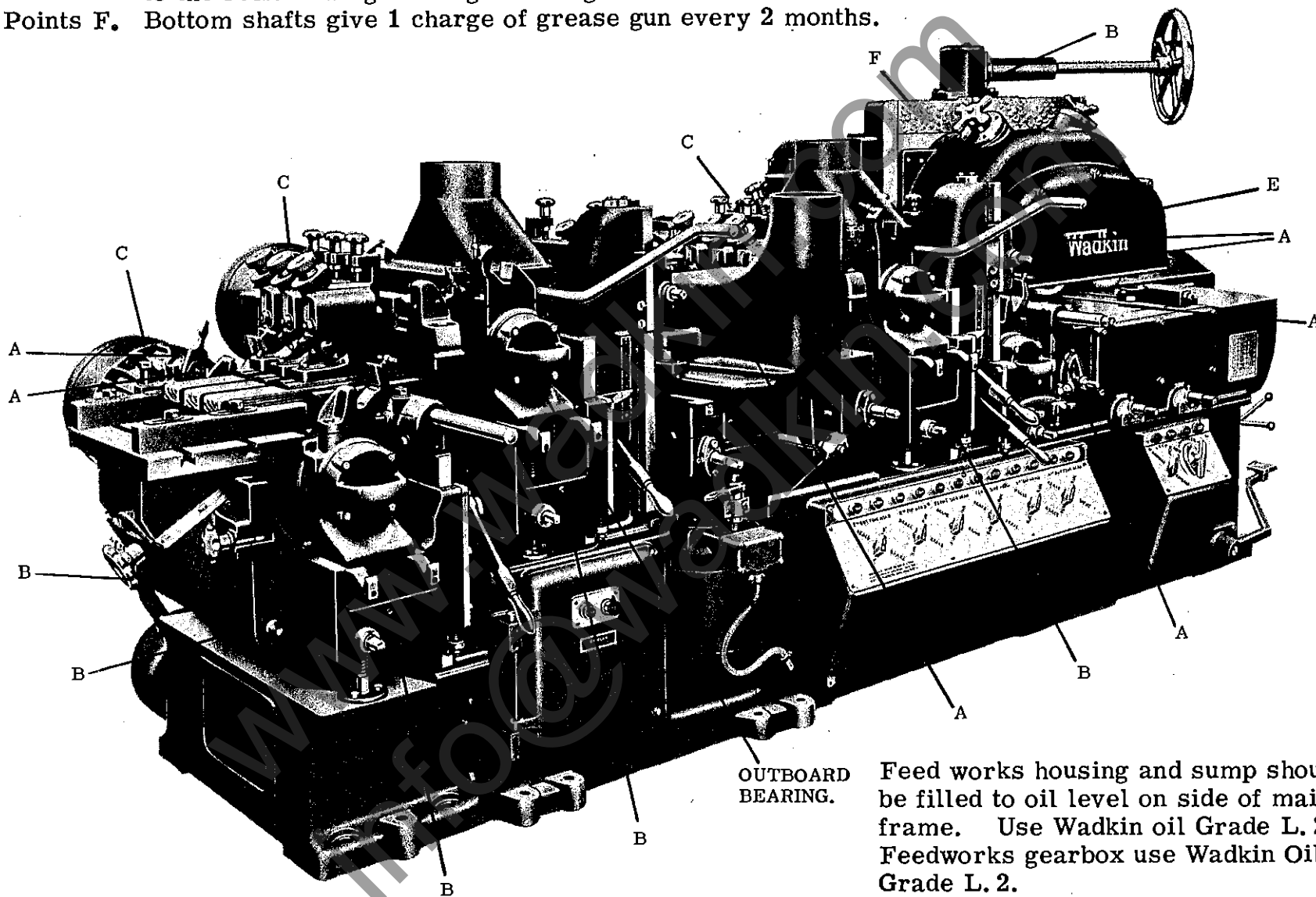

OUTBOARD BEARING.

Feed works housing and sump should be filled to oil level on side of main frame. Use Wadkin oil Grade L. 2. Feedworks gearbox use Wadkin Oil Grade L. 2.

POSITION ON MACHINE	MAKERS NO.	QUANTITY	BORE	O/DIA.	THICKNESS	
FEEDWORKS	Bottom Rolls	SKF 2309	4	45 mm	100 mm	36 mm
	Idler Sprockets (inside feed)	SKF 6207	4	35 mm	72 mm	17 mm
	Top Roll Shaft	SKF CRL 11	2	1 $\frac{3}{8}$ "	3"	11/16"
	Top Roll Shaft	SKF 2311	2	55 mm	120 mm	43 mm
	Top Roll Shaft	SKF 2309	2	45 mm	100 mm	36 mm
	Top Roll Pivot Shaft	SKF RLS 13	4	1 $\frac{5}{8}$ "	3 $\frac{1}{2}$ "	$\frac{3}{4}$ "
	Feed Raise & Fall Shaft	SKF 6206	1	30 mm	62 mm	16 mm
	Btm. Roll Main Drive Shaft	SKF 2309	1	45 mm	100 mm	36 mm
	Btm. Roll Main Drive Shaft	SKF CRL 11	11	1 $\frac{3}{8}$ "	3"	11/16"
	Raising Screw	SKF 09	1	1 $\frac{1}{8}$ "	1.29/32"	$\frac{5}{8}$ "
	Raising Screws	SKF 010	2	1 $\frac{1}{4}$ "	2.3/32"	23/32"
	Outboard Brg. Unit	HOFF.1071	1	55 mm	100 mm	21 mm
	Top Pressure Over 1st. Btm. Head	SKF 010	2	1 $\frac{1}{4}$ "	2.3/32"	23/32"
		Raising Screws	SKF 08	4	1"	1 $\frac{3}{4}$ "
Outboard Brg. Unit		HOFF.1071	2	55 mm	100 mm	21 mm
Raising Screws		SKF 08	2	1"	1 $\frac{3}{4}$ "	5/8"
Outboard Brg. Unit		HOFF.1071	1	55 mm	100 mm	21 mm
Horizontal Spindles	per	SKF 402353	1	30 mm	62 mm	16 mm
	spindle	HOFF.1074	2	55 mm	120 mm	29 mm
Vertical Spindles	per	SKF 402353	1	30 mm	62 mm	16 mm
	spindle	HOFF.1071	1	55 mm	100 mm	21 mm
	spindle	HOFF.1072	1	45 mm	100 mm	25 mm
Top Pressures Over Front Side Hd.	SKF 010	2	1 $\frac{1}{4}$ "	2.1/16"	23/32"	
Gear Box		SKF RMS 10	7	1 $\frac{1}{4}$ "	3 $\frac{1}{8}$ "	7/8"
		SKF RMS 13	2	1 $\frac{5}{8}$ "	4"	15/16"
		SKF 6309	1	45 mm	100 mm	25 mm
Frequency Changer MZ 6335 D.E.		HOFF. MS 14V	1	1 $\frac{3}{4}$ "	4 $\frac{1}{4}$ "	1.1/16"
	N.D.E.	HOFF. MS 14V	1	1 $\frac{3}{4}$ "	4 $\frac{1}{4}$ "	1.1/16"
Drive Motor KZ 4836	D.E.	HOFF. RMS 13	1	1 $\frac{1}{2}$ "	3 $\frac{3}{4}$ "	15/16"
	N.D.E.	HOFF. MS 13V	1	1 $\frac{1}{2}$ "	3 $\frac{3}{4}$ "	15/16"
Feed Motor B.256	D.E.	HOFF. R 335	1	35 mm	80 mm	21 mm
	N.D.E.	HOFF. 335	1	35 mm	80 mm	21 mm

FENCE BEFORE FEED ROLLS.

THIS FENCE IS FIXED TO TAKE INFEED TABLE.

FENCE OVER FEED ROLLS.

THIS FENCE IS FIXED AND IS BOLTED TO THE REAR BOTTOM ROLL HOUSING.

FENCE UNDER 1ST. TOP HEAD.

THIS IS FIXED TO THE TABLE AND IS FITTED WITH AN ADJUSTABLE NOSE SHOE, THE FENCE SHOE IS SLOTTED TO ENABLE CUTTERBLOCKS FROM 6½" TO 9" TO BE USED.

FENCE AFTER NEAR FENCE HEAD.

THIS IS FITTED WITH TWO LINKS AND CAN BE MOVED IN OR OUT. THE NUTS (A) SHOULD BE SLACKENED AND THE FENCE MOVED TO THE DESIRED POSITION AND RE-LOCKED.

THE LINKS MECHANISM ENSURES THAT THE ADJUSTABLE FENCE IS PARALLEL TO FIXED FENCES.

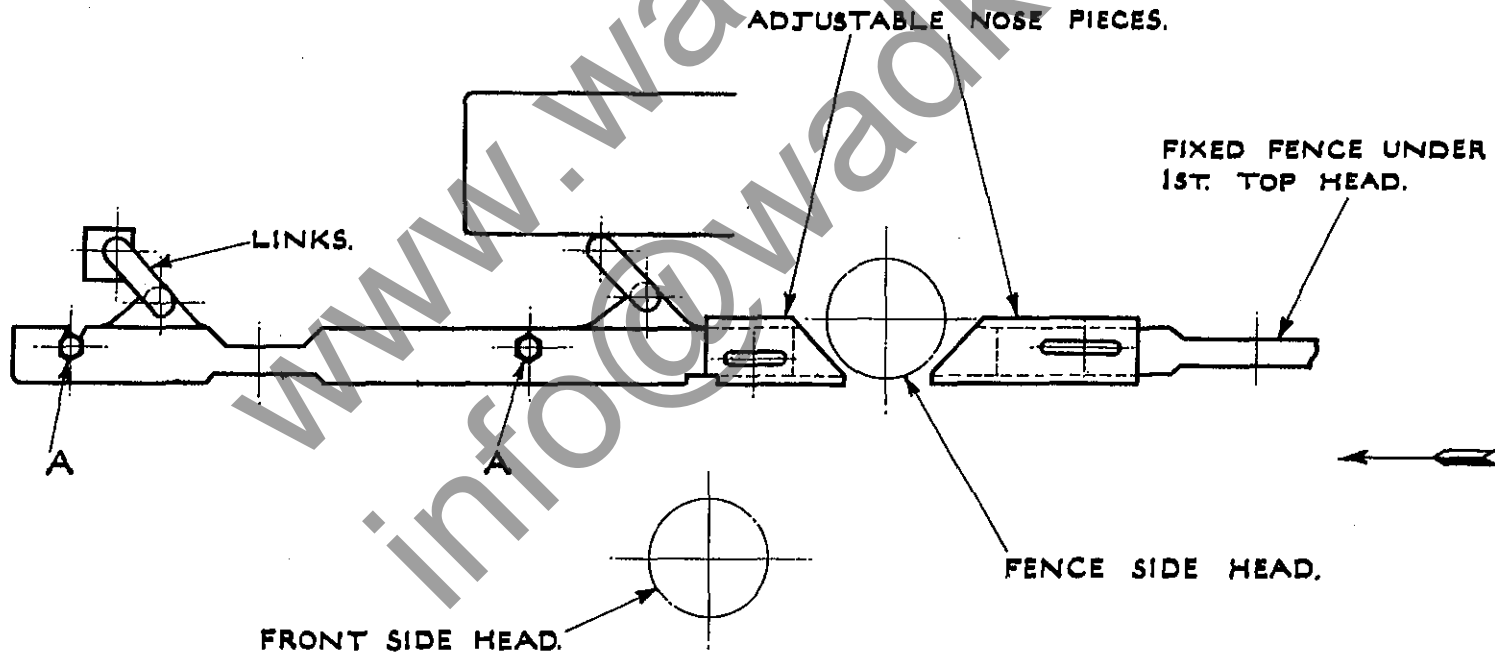

SEE SECTION E, TOOL & SUNDRIES
FOR RANGE OF BLOCKS.

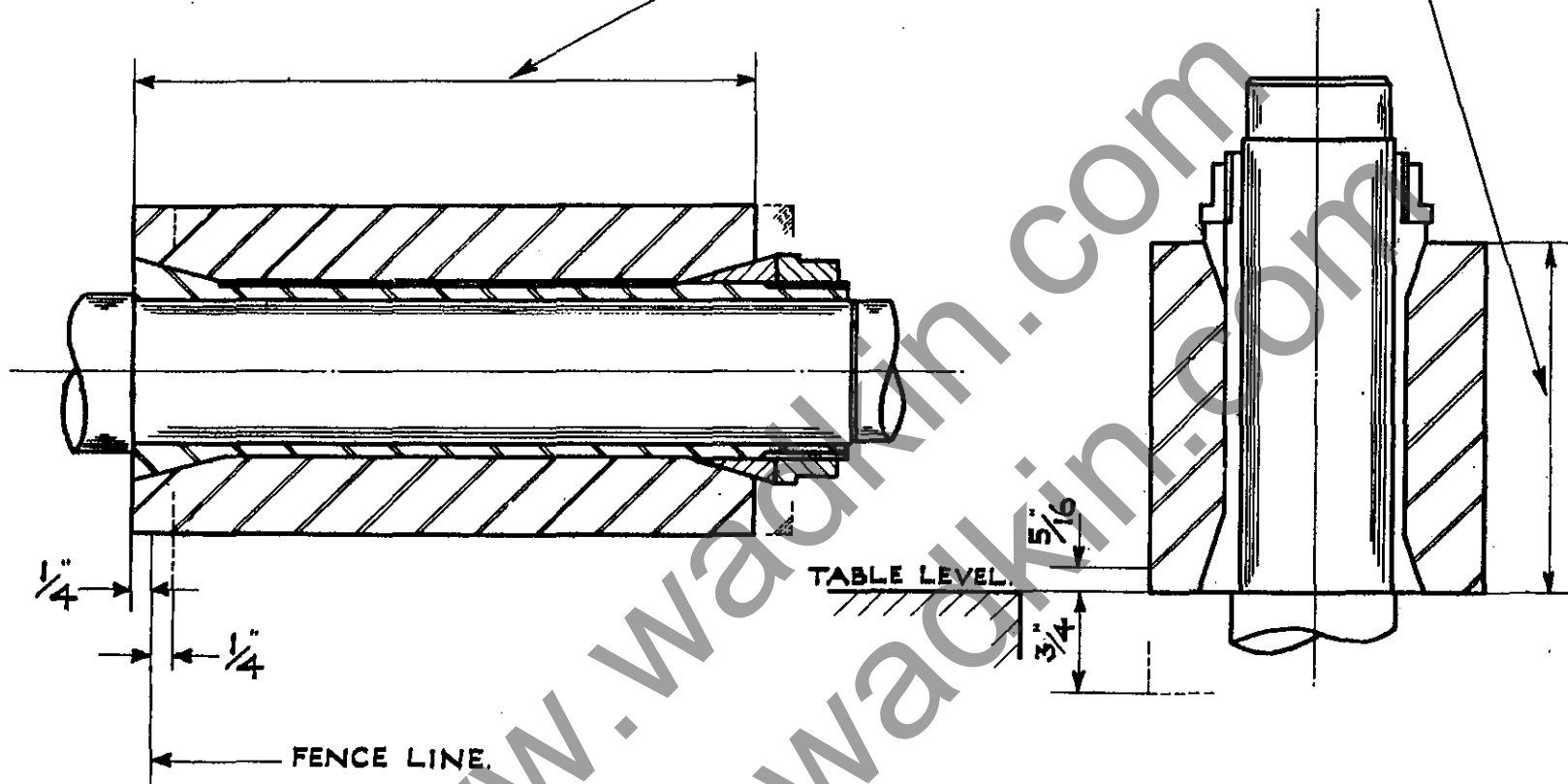

SECTION SHOWING ADJUSTMENT OF HORIZONTAL AND VERTICAL SPINDLES.

LUBRICATION INSTRUCTIONS.

FEEDWORKS.

Remove front top roll cover and four grease nipples for the top swings also two oil nipples of the pivot shafts. Grease nipples are fitted on the bottom rear roller blocks, also two oil nipples on the fence for oiling the rear roller block slides. One grease nipple on the rear bottom roll housing for greasing of main input roller bearing. Two grease nipples on the front bottom roll blocks. Oil the pins and links supporting the centre table between feed rolls. Two oiling points on the bottom roll adjusting screw. See that the top raising worm box is packed with grease on the feedworks housing. Three oiling points on the supporting bracket for top feed roll adjustment. Gear box drive top up with oil, dipstick is fitted on the front of the box. Remove rear top feedworks cover (take care in supporting the weight of the cover.) Grease nipples on the top roll shaft ends and top up main feedwork sump oil sight on the main frame. Oil or grease on the points on the top or bottom spindle carriages.

HORIZONTAL AND VERTICAL CUTTER SPINDLES - IMPORTANT.

The cutter spindles must be lubricated daily with Wadkin Grade L.1. oil and grease for the tail end of all spindle motor ends (See pages)

LUBRICATION INSTRUCTIONS

Feed Works

The top roller swing hinge pins are fitted with oil cups and every three months the top feed roller front cover should be removed and these oil cups filled with Wadkin Grade 4 oil. The chain drive picks up oil from the sump in the feed works housing, and the sump should be filled to the oil level weekly, using Wadkin Grade L2 oil. The filler oil level and drain plug is fitted to the main frame. The worm gear runs in an oil bath and the worm box oil level should be "topped up" weekly to the oil level using Wadkin Grade L2. The spiral gearbox on the feed works housing for raising and lowering the top feed rolls is fitted with a 90° tip-up oiler and the oil level should be checked weekly and "topped up" if necessary to the top of the oiler using Wadkin Grade L4 oil. The tip-up oiler on the handwheel shaft boss requires three to four drops of Wadkin Grade L4 oil weekly.

As will be seen from the lubrication instructions Wadkin oils and greases are recommended, but if it is desired to use lubricants other than Wadkin the following equivalents are listed below:-

Wadkin Grade	Equivalents
Spindle oil, Grade L.1.	Mobil oil D.T.E. (Light) or Shell Vitrea oil 27.
Gear oil, Grade L.2.	Mobil oil D.T.E./B.B. or Shell Vitrea oil 69.
Machine oil, Grade L.4.	Mobil 'Vactra' oil (Heavy Medium) or Shell Vitrea oil 33
Ball bearing grease, Grade L.6.	Mobil grease B.R.B. No.1. or Shell Nerita grease 3.

IMPORTANT

Cutter Spindles

The horizontal cutter spindles must be lubricated daily. Fill to the top of oil cup shown in Page 6 with Wadkin L4 oil and give one depression of the grease gun weekly to the nipple at the motor end of the spindle, using Wadkin Grade L6 grease. A drain plug is fitted under the oil cup to drain away surplus oil. The vertical cutter spindles shown Page 10 should be lubricated by removing the plug marked 'OIL' at the top of the spindle and filled daily with Wadkin Grade L4 oil. A pipe is fitted to the vertical heads to drain away surplus oil. Give one depression of the grease gun weekly, using Wadkin grease Grade L6 to the nipple at the motor end of the cutterspindle.

JOINTERS.

Horizontal and vertical joints can be supplied to special order.

SETTING-UP STAND.

Setting-up stand for square and circular cutterblocks can be supplied, to special order.

SLITTING SAWS.

Slitting saws can be fitted. The maximum diameter of the saw is $10\frac{1}{2}$ ". When ordering customer MUST state number of saw to be worked, width and depth of cut.

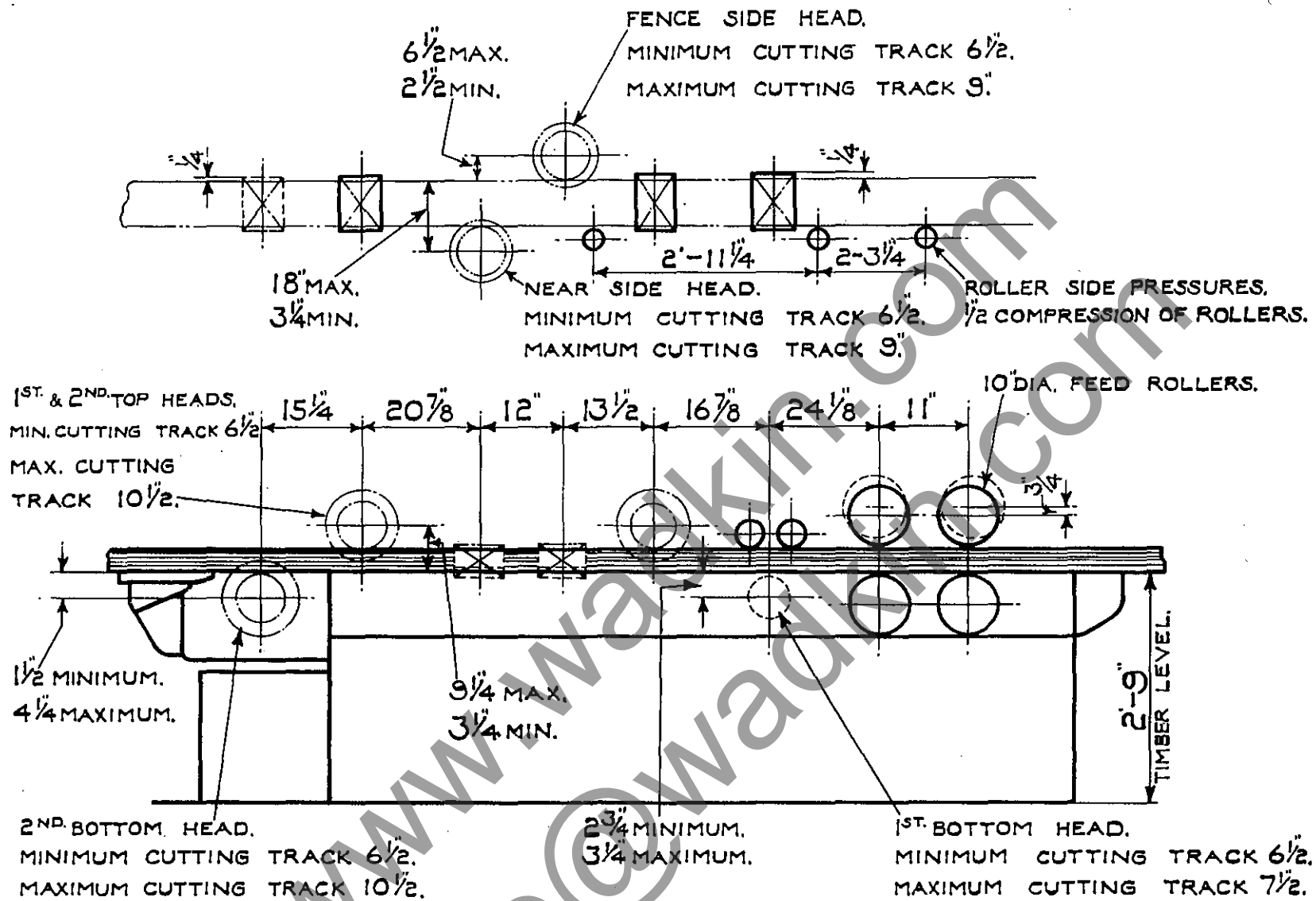

CAPACITY DIAGRAM FOR 12"x5" OR 12"x6" MOULDER - TYPE FD.

Remove feedworks rear cover. Take care in supporting.
Feed a piece of timber under feed rolls. Stop machine
and grease ends of top roll shafts every 3 months.

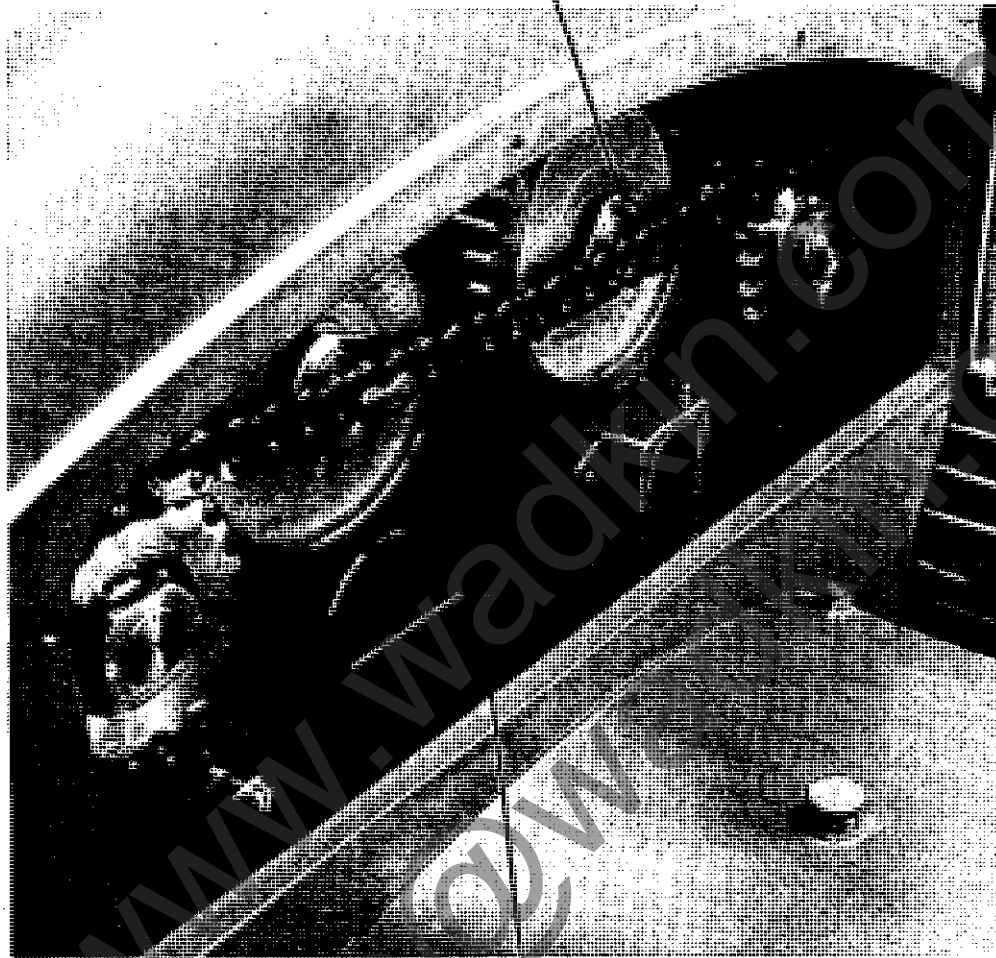

Oil chute for main bearing and rear bottom roll driving gears.
Remove front top roll cover and grease out-board bearing cap,
every three months.
Remove bedplate before 1st. bottom head take off sheet iron cover
and oil gear and screw every three months.

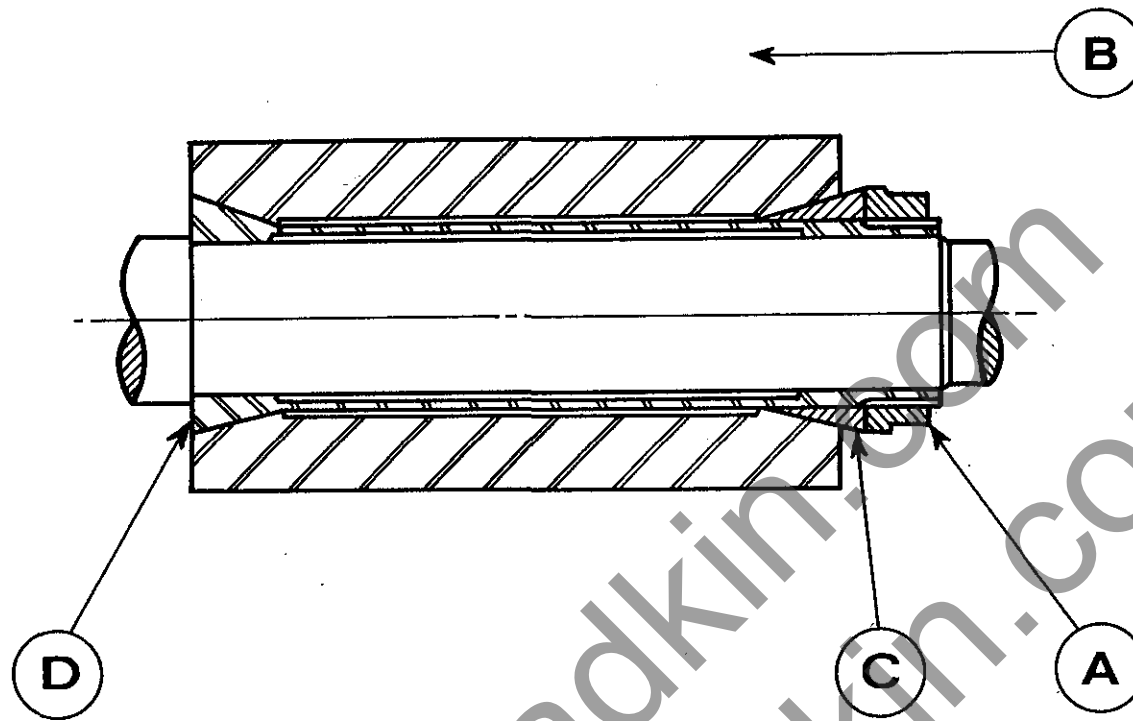

SECTION THROUGH SPINDLE

TO REMOVE CUTTERBLOCK FROM SPINDLE, EITHER HORIZONTAL OR VERTICAL,
PROCEED AS FOLLOWS:

UNSCREW NUT (A)

TAP BLOCK HOME IN DIRECTION OF ARROW (B) USING A MALLETT. THIS
SHOULD RELEASE CONE (C).

REMOVE CONE (C).

TAP BLOCK OFF SLEEVE IN OPPOSITE DIRECTION TO ARROW (B).

FINALLY REMOVE SLEEVE (D).

TO RE-ASSEMBLE REVERSE THE ABOVE PROCEDURE.

Pneumatic Feed

This machine is provided with pneumatic lift to top feed rolls. It will allow $\frac{3}{4}$ " timber variation in timber thickness without altering the main roller setting. Mounted on the top roll swings are pneumatic cylinders which are supplied through a control valve in the main control box, which is positioned on the machine feed works. These cylinders may be cushioned by adjustment of flow regulator mounted on both up and down strokes. The control valve is operated by the push buttons on the main control box. The Yellow one raising the rolls and the Blue one lowering the rolls.

The main air pressure at the filter and lubricator should be set at 80lbs/sq. in. Mounted on the main control box is a balance valve which should be set to 40lbs/sq. in. by balancing out with a knob, on the front of the panel until the required pressure is obtained and no air is escaping through the valve.

The top rolls should be set up to the thickness being fed, indicated on the scale at the side of the feed works housing, with rolls in up position. To operate feed rolls:-

1. Start frequency changer. This will energise the solenoid valve, permitting pilot air to flow to the control buttons.
2. Then start machine in normal manner.
3. Feed in under the top feed rolls, the first piece of timber and then bring down the rolls on the timber.
4. Set up and feed in normal way.

When feeding, if timber slips, the boost pressure button can be pushed to give full line pressure to the feed rolls. If the slipping continues, the balance valve should be adjusted to give more pressure to stop slipping.

NOTE

When the master stop button is depressed, the solenoid valve is de-energised and the top rolls are automatically raised and inoperative.

When a timber gate is fitted (to special order) this should be set just above the normal thickness of the timber being fed. If a piece of oversized timber is fed in, the rolls will raise and become inoperative.

An overload cut-out can be incorporated in any head motor circuit to special order. The solenoid valve is then connected to this cut-out so that if the head is overloaded, the solenoid is de-energised and lifts the rolls.

The trip amps adjuster on the overload must be set at a point just above the motor starting current. No oil is required in this adjuster as undamp action is required.

The pneumatic circuit is protected under British Patent No. 986651 and is shown in diagram FD. 10069, 8" FD.

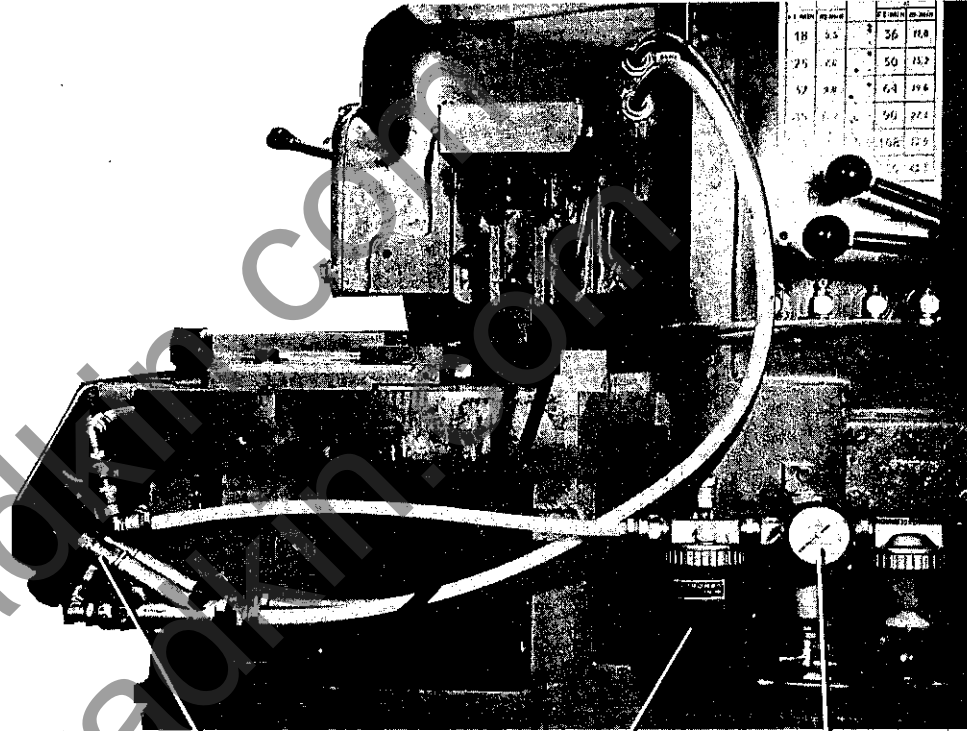
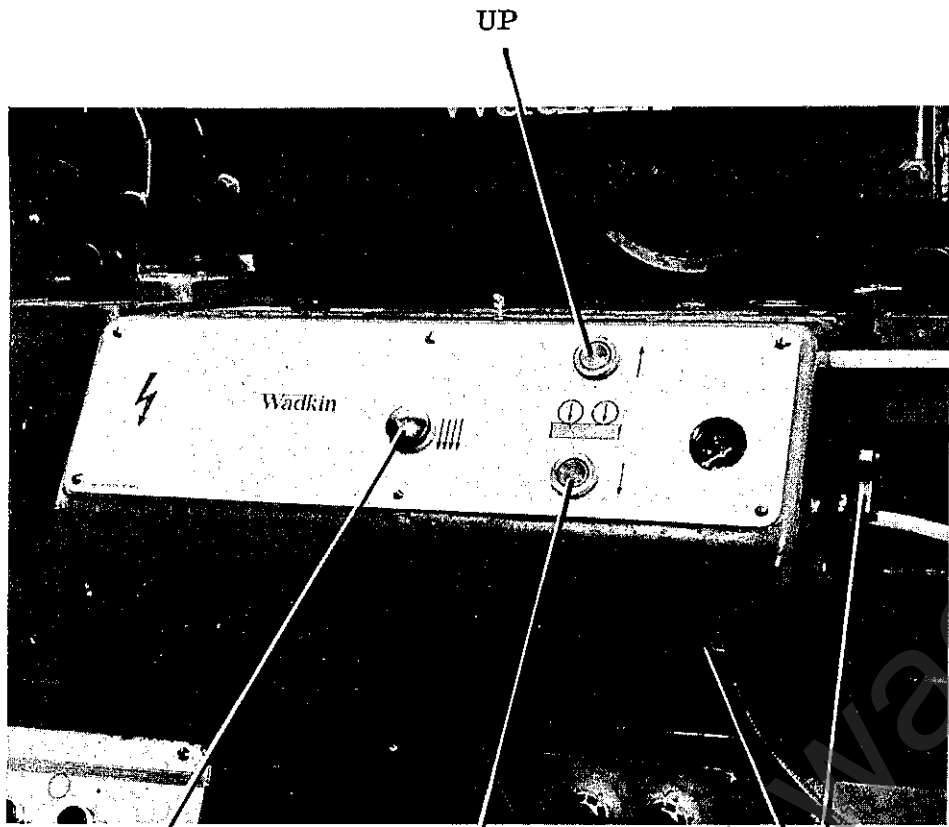

BOOSTER

DOWN

BALANCE CONTROLS

FLOW REGULATORS

FILTER LUBRICATOR

USE MOBIL ALMO OIL No. 1.

www.wadkin.com
info@wadkin.com